

Description	The volume booster amplifies the volume at a 1:1 ratio of pilot pressure to outlet pressure. The pilot pressure has no constant bleed and shows the same function as a spring in a common regulator: generating counter pressure on the diaphragm. This force is compensated by the outlet pressure on the diaphragm's bottom side. The ratio of pilot pressure to outlet pressure depends on the size of the operating diaphragms.		
Media	compressed air or non-corrosive gases	Supply pressure	max. 17 bar
Pilot pressure	max. 10 bar at 1:1, 2:1 and 3:1 ratio, 5 bar at 1:2,	pilot port:	G $\frac{1}{4}$
Accuracy	at supply pressure variation of 7 bar: < 7 mbar pressure deviation response sensitivity: 2.5 mbar		
Internal air consumption	max. 3 l/min, depending on outlet pressure	Relieving function	relieving
Relief capacity	1100 l/min at 0.35 bar overpressure above setpoint	Mounting position	any
Gauge port	G $\frac{1}{4}$ on both sides of the body, screw plugs supplied		
Temperature range	0 °C to 90 °C / 32 °F to 194 °F, for appropriately conditioned compressed air down to -40 °C / -40 °F		
Material	Body: aluminium die-cast Inner valve: brass and aluminium	Elastomer:	NBR/Buna-N, optionally FKM

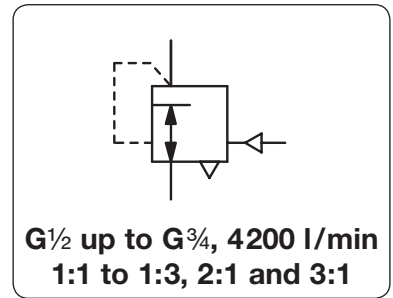

Dimensions			K _v -value	Flow rate	Connection thread	Pilot pressure max. bar	Transmission ratio signal : outlet	Order number
A	B	C						

Booster			with transmission ratio, supply pressure max. 17 bar relieving, with constant bleed, pressure range 0...10 bar				R450		
87	129	40	2.16	240	4000	G $\frac{1}{2}$	10	1 : 1	R450-04I
							5.0	1 : 2	R450-04K
							3.3	1 : 3	R450-04L
							10	2 : 1	R450-04M
							10	3 : 1	R450-04N
87	129	40	2.16	252	4200	G $\frac{3}{4}$	10	1 : 1	R450-06I
							5.0	1 : 2	R450-06K
							3.3	1 : 3	R450-06L
							10	2 : 1	R450-06M
							10	3 : 1	R450-06N



R450

Special options, add the appropriate letter

NPT	connection thread	R450-0..N
tapped exhaust	G $\frac{1}{2}$ connection thread, total height 148 mm	R450-0..X12
bypass with restrictor	from control chamber to outlet	1:1 only R450-0..X16
external feedback	with connection thread G $\frac{1}{8}$	R450-0..X27
FKM elastomer		R450-0..V

Accessories, enclosed

pressure gauge	Ø 63 mm, 0... ^{*2} bar, G $\frac{1}{4}$	MA6302-..*2
mounting bracket	made of steel	BW00-47

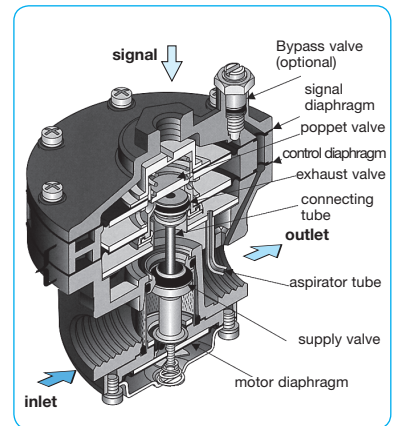

cross section

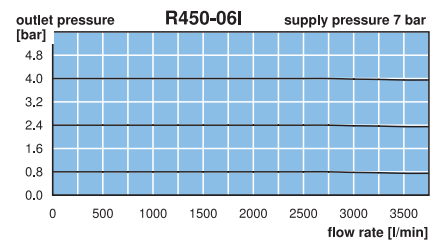
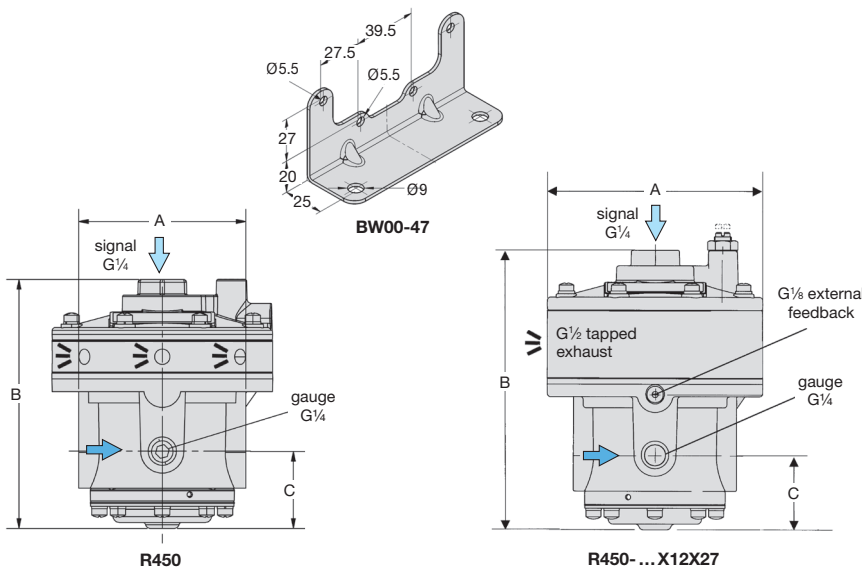

*1 at 7 bar supply pressure and 1.4 bar outlet pressure
*2 02 = 0...2.5 bar, 04 = 0...4 bar, 06 = 0...6 bar, 10 = 0...10 bar, 16 = 0...16 bar

Gauges: see chapter for measuring devices

PDF CAD
www.aircom.net

Order example:
R450-04I